

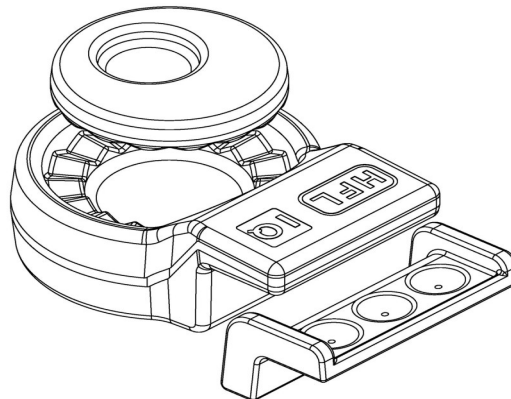

LothEx

Adjustable rail clip with form fitted rubber cap
- Smart fixing of crane rails -



- ✓ universal, in four sizes for all types of rails
- ✓ easy mounting
- ✓ reliable positioned by teether washer
- ✓ form fitting side guide
- ✓ lateral adjustable
- ✓ reduces noise and vibrations in all axes
- ✓ completely electrical insulating
- ✓ chemical stability against oil and grease
- ✓ reliable quality Made in Germany
- ✓ **Approved by EBA, German railways authority**

Do not hesitate to contact us: we will make an individual offer to you!

Your Hagen F. Lothes Team



LothEx.Technical Data

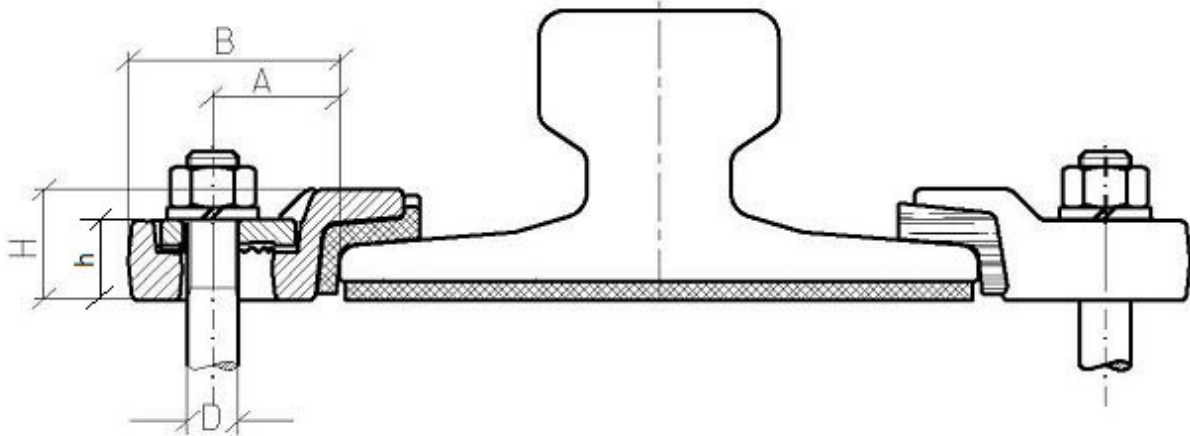

Type	i.e. for rails:	A*	B	H **	h**	D	Adjustment range
M1	A45, A55, A65, S33, S41	30mm	55mm	28mm	21mm	M12	±3,5mm
M2	A65, A75, A100, S33, S41, S49, S54, UIC60	35mm	65mm	35mm	25mm	M16	±5mm
M3	A100, A120, S54, UIC60	45mm	85mm	34,5mm	31,5mm	M20	±7,5mm
M4	AS86, MRS87A, MRS125A	45mm	85mm	40mm	38mm	M24	±7,5mm
* With central setting of the side adjustment				** Designed for use with a 6 mm rubber layer. Flat clips for use without rubber layer on request.			

thread diameter	thread grade	recommended tightening torque	typical lateral force**
M12	4.6	32 Nm	10 kN
	8.8	86 Nm	26 kN
M16	4.6	80 Nm	19 kN
	8.8	215 Nm	50 kN
M20	4.6	155 Nm	30 kN
	8.8	420 Nm	80 kN
M24	4.6	270 Nm	42 kN
	8.8	720 Nm	110 kN

** The typical lateral forces apply per support point on the clamp with continuous support. They only serve as a reference value and do not replace a static verification.